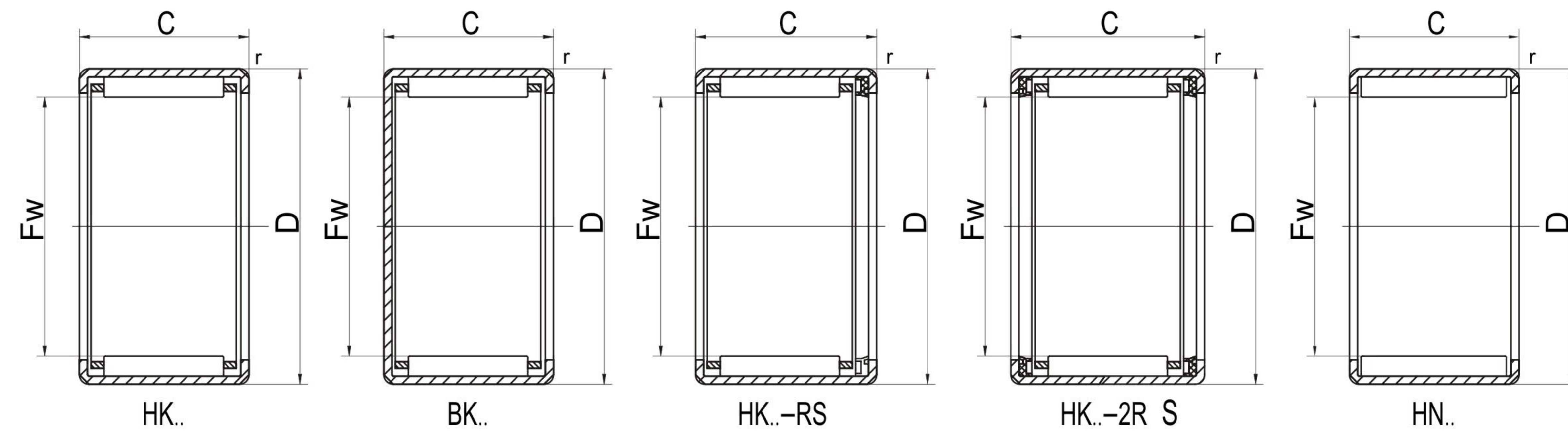

图示 Illustration

产品介绍:

XH冲压外圈滚针轴承有穿孔型、封口型等多种结构，其径向截面高度较小，外圈和保持架用金属冲压成型方法制造。轴承的滚针轮廓面设计有修形，可有效地避免产生有破坏性的边缘应力。根据需要，可以在轴承外圈上设置润滑油孔，以实施对轴承的润滑。且可提供穿孔型或封口型带有油封装置的轴承，以解决由于空间限制无法安装油封的问题，其间充填具有良好润滑及防锈性能的锂基润滑脂。

Product introduction:

XH provides drawn cup needle roller bearings, mainly open end type and closed end type, of which the height of radial section is short, and outer rings and cages are made by metal punching forming. Profiles of needles are modified to avoid destructive edge stress. Oil holes can be arranged on outer rings for bearing lubrication if required. Besides, bearings with oil sealing devices are available in order to solve the problem of lacking space for oil seals, which is filled with grease of good lubricity and rust resistance.

基本尺寸(mm) Basic dimension		基本额定载荷(mm) Basic load rating		极限转速脂油 Limit speed Grease / Oil		轴承代号 Bearing designation		重量 Weight		
Fw	D	C	Cr	Cor	min-1		HK	BK	W≈g	
10	14	8	2.9	3.2	11000	17000	HK 1008	BK 1008	2.9	3.2
	14	9	3.4	4	11000	17000	HK 1009	BK 1009	3.1	3.5
	14	10	3.9	4.8	11000	17000	HK 1010	BK 1010	3.6	3.9
	14	12	4.9	6.4	11000	17000	HK 1012	BK 1012	4.4	4.8
	14	14	5.8	8	11000	17000	HK 1014	BK 1014	5.3	5.6
12	16	8	3.1	3.8	9500	15000	HK 1208	BK 1208	3.3	3.8
	16	9	3.7	4.7	9500	15000	HK 1209	BK 1209	3.7	4.2
	16	10	4.3	5.6	9500	15000	HK 1210	BK 1210	4.1	4.6
	16	12	5.3	7.5	9500	15000	HK 1212	BK 1212	5.1	5.5
	16	14	6.3	9.4	9500	15000	HK 1214	BK 1214	6	6.5
12.7	17.462	9.525	4.4	5	9500	15000	SCE 86	HK	9.4	
	17.462	12.7	6.4	8.1	9500	15000	SCE 88	HK	10.1	
14	20	10	4.9	5.8	9500	15000	HK 1410	BK 1410	8.3	9.6
	20	12	6.3	8.1	9500	15000	HK 1412	BK 1412	10.1	11.3
	20	12	13.3	18.9	9500	15000	FY-1412	FY	105	
	20	14	7.7	10.5	9500	15000	HK 1414	BK 1414	12	13.2
	20	16	9	12.8	9500	15000	HK 1416	BK 1416	13.9	15.2
	20	18	10.2	15	9500	15000	HK 1418	BK 1418	15.6	16.9
14.288	20	20	11.5	17.2	9500	15000	HK 1420	BK 1420	17.5	187.7
	20	25	11.8	15.8	9500	15000	HK 14x20x25-2RS	HK-2RS	20	
	19.05	19.05	7.9	10.9	9000	14000	SCE 0912-2RS	HK-2RS	18.5	
17	23	10	5.5	7.1	8000	12000	HK 1710	BK 1710	9.3	11.2
	23	12	7.1	9.9	8000	12000	HK 1712	BK 1712	11.5	13.4
	23	12	14.7	22.9	8000	12000	FY-1712	FY	11.8	
	23	14	8.6	12.8	8000	12000	HK 1714	BK 1714	13.7	15.6

基本尺寸(mm) Basic dimension		基本额定载荷(mm) Basic load rating		极限转速脂油 Limit speed Grease / Oil		轴承代号 Bearing designation		重量 Weight		
Fw	D	C	Cr	Cor	min-1		HK	BK	W≈g	
17	23	15	7.8	9.8	8000	12000	HK 1715-RS	HK-RS	18.8	
	23	16	10.2	15.5	8000	12000	HK 1716	BK 1716	15.9	17.7
	23	17	5.3	5.9	8000	12000	HK 1717-RS	HK-RS	17.5	
	23	18	11.5	18.5	8000	12000	HK 1718	BK 1718	18.1	19.9
	23	20	13.5	22.5	8000	12000	HK 1720	BK 1720	20.5	22.4
	24	12	16.3	22.2	8000	12000	FY-172412	FY型	22.9	
	24	15	10.3	12.1	8000	12000	HK 17x24x15	HK型	24.5	
	24	17	22.6	33.8	8000	12000	FY-172417	FY型	25.1	
	24	20	13.6	17.2	8000	12000	HK 17x24x20-RS	HK-RS型	28.9	
	24	20	26.2	40.8	8000	12000	FY-172420	FY型	28.6	
	24	25	32.1	52.3	8000	12000	HK 17x24x25	HK型	30.5	
	24	25	18.7	26.1	8000	12000	HK 17x24x25-RS	HK-RS型	31.9	
	24	25	31.8	52.5	8000	12000	FY-172425	FY型	30.9	
	24	30	21.8	31.8	8000	12000	HK 17x24x30-RS	HK-RS型	37.5	
17.462	22.225	9.525	5.2	6.7	8000	12000	SCE 116	HK型	10.6	
18	24	10	5.6	7.5	7500	11000	HK 1810	BK 1810	9.9	12
	24	12	7.3	10.5	7500	11000	HK 1812	BK 1812	12.1	14.2
	24	14	8.9	13.5	7500	11000	HK 1814	BK 1814	14.5	16.5
20	26	20	25.4	49	7000	10000	FY-2020	FY型	24.8	
	27	15	21.9	34.1	7000	10000	FY-202715	FY型	29.8	
	27	20	16.9	24.3	7000	10000	HK-20x27x20	HK型	31.4	
	27	20	28.5	47.9	7000	10000	FY-202720	FY型	33.8	
	27	23.5	18	26.3	7000	10000	HK 20x27x23.5-RS	HK-RS型	38.5	
	27	25	34.6	61.5	7000	10000	FY-202725	FY型	39	
	27	30	40.5	75.4	7000	10000	FY-202730	FY	42.6	
	27	32	33.9	60	7000	10000	FY-202732K-2RS	FL-2RS	48.6	
21	26	30	22.2	40	7000	10000	HK 2030	HK	33.4	
	27	20	26.3	51.5	6700	10000	FY-2120	FY	18.9	
22	35	27	35.2	36.6	6700	10000	HKS 21x35x27		80.5	
	28	10	6.3	9.3	6700	9500	HK 2210	BK 2210	11.7	14.8
	28	12	8.2	13	6700	9500	HK 2212	BK 2212	14.4	17.5
	28	14	10	16.8	6700	9500	HK 2214	BK 2214	17.2	20.2
	28	16	11.8	20.5	6700	9500	HK 2216	BK 2216	19.9	22.9
	28	16	22.4	41.8	6700	10000	HK 2216	FY型	20.8	
	28	18	13.2	24.2	6700	9500	HK 2218	BK 2218	22.5	25.6
	28	20	15	27.8	6700	9500	HK 2220	BK 2220	25.3	28.4
	28	20	27.2	54	6700	10000	FY-2220	FY型	24.4	
	29	20	18.1	27.3	6700	10000	HK 22x29x20	HK型	28.4	
28	29	30	27.6	40	6700	10000	HK 22x29x30	HK型	34.6	
	30	18	17.2	24.6	6700	10000	HK 22x30x18	HK型	31	
	35	12	9.5	14.5	6300	9000	HK 2812	BK 2812	20	24.9
	35	14	12	19.5	6300	9000	HK 2814	BK 2814	24	29
	35	16	14.2	24.2	6300	9000	HK 2816	BK 2816	27.6	32.6
	35	18	16.2	29.2	6300	9000	HK 2818	BK 2818	31.7	36.6
28.575	35	20	18.5	34	6300	9000	HK 2820	BK 2820	35.5	40.5
	35	24	22.5	43.5	6300	9000	HK 2824	BK 2824	43.2	48.1
	36	18	15.4	24.1	6000	8500	SCE 188	HK型	23.3	
29	36	18	15.4	24.1	6000	8500	HK 2931618-RS	HK-RS型	25.6	
	37	12	10	15.8	5600	8000	HK 3012	BK 3012	21.4	27.1
30	37	14	12.5	21.2	5600	8000	HK 3014	BK 3014	25.5	31.2

XH 冲压外圈滚针轴承
Drawn cup needle roller bearing

基本尺寸(mm) Basic dimension			基本额定载荷(mm) Basic load rating		极限转速脂油 Limit speed Grease / Oil		轴承代号 Bearing designation		重量 Weight	
Fw	D	C	Cr	Cor	min-1		HK	BK	W≈g	
25	32	36	23	43.6	6300	9000	HK 2536-2RS	HK-2RS型	45.2	
	37	18	23.9	30.5	6300	9000	HK 25x37x18	HK型	48.6	
	44.5	19	37.4	36.3	6300	9000	HK 2544.519K	HKN型	56.2	
25.4	31.75	20.638	17.5	28.2	6300	9000	SCE 1613-RS	HK-RS型	28.1	
	31.75	22.225	17.5	28.2	6300	9000	SCE 1614-2RS	HK-2RS型	31.5	
27	34	20	18.9	30.6	6300	9000	HK 27x34x20	HK-RS型	28.1	
	34	20	14.5	21.7	6300	9000	HK 27x34x20-2RS	HK-2RS型	31.5	
28	33.82	19	17.5	27.9	6300	9000	HK 28x33.82x19/YA	HK型	33.2	
32	39	12	10.5	17.2	5300	7500	HK 3212	BK 3212	22.7	29.2
	39	14	13.2	23	5300	7500	HK 3214	BK 3214	27.2	33.7
	39	16	15.5	28.5	5300	7500	HK 3216	BK 3216	31.3	37.8
	39	18	18	34.2	5300	7500	HK 3218	BK 3218	35.8	42.3
	39	20	20.2	40	5300	7500	HK 3220	BK 3220	40.4	46.8
	39	24	24.5	51.5	5300	7500	HK 3224	BK 3224	49	55.5
	39	34	39.5	84	5300	7500	HK 32x39x34	HK型	56.5	
	41	16	19.8	27.2	5300	7500	HK 32x41x16	HK型	44.5	
44	17	19.3	15.2	5300	7500	HK 32x44x17	HK型	43.5		
34.925	41.295	12.7	12.3	19.9	5000	7000	SCE 228	HK型	23.6	
35	42	12	10.8	18.5	5000	7000	HK 3512	BK 3512	24.5	32.3
	42	14	13.5	24.5	5000	7000	HK 3514	BK 3514	29.3	37.1
	42	16	16.2	30.8	5000	7000	HK 3516	BK 3516	33.9	41.6
	42	18	18.5	37	5000	7000	HK 3518	BK 3518	38.7	46.4
	42	20	21	43.2	5000	7000	HK 3520	BK 3520	43.5	51.2
	42	24	25.5	55.5	5000	7000	HK 3524	BK 3524	52.8	60.5
	42	30	27.9	63.5	5000	7000	HK 3530	HKN型	55.4	
	43	22	27.2	48	5000	7000	HK 35x43x22	HKN型	57.1	
	43	25	33.1	60.2	5000	7000	HK 354325	HKN型	58.2	
	44	20	24.9	42.5	5000	7000	HK 35x44x20	HKN型	59.6	
44	30	41.9	73.3	5000	7000	HK 35x44x30	HKN型	60.5		
45	26	36.8	18	5000	7000	HMK 3526	HKN型	61.2		
42	49	20	23.2	52.2	4300	6000	HK 4220	BK 4220	51.4	62.5
	49	22	23.3	46.5	4300	6000	HK 42x49x22-2RS	HK-2RS型	54.3	
	49	24	28.2	67.2	4300	6000	HK 4224	BK 4224	62.5	73.6
	52	20	35.5	96	4300	6000	FY-425220	FY型	72.1	
45	52	12	12.2	23.8	3800	5300	HK 4512	BK 4512	30.8	43.5
	52	14	15.5	31.8	3800	5300	HK 4514	BK 4514	36.8	49.5
	52	16	18.8	39.5	3800	5300	HK 4516	BK 4516	42.5	55.2
	52	18	21.2	47.5	3800	5300	HK 4518	BK 4518	48.6	61.3
	52	20	24	55.5	3800	5300	HK 4520	BK 4520	54.7	67.4
	52	24	29	71.2	3800	5300	HK 4524	BK 4524	66.4	79.1
52	25	53.5	140.7	3800	5300	FY-4525	FY型	67.1		
47	53	22	23.4	53.3	3600	5000	HK 47x53x22-2RS	HK-2RS型		
50	58	12	16.3	27.1	3400	4800	HK 5012	HK型	50.9	
	58	16	21.2	43.5	3400	4800	HK 5016	BK 5016	52.7	68.4
	58	18	24.5	52.2	3400	4800	HK 5018	BK 5018	60	75.6
	58	20	27.8	61	3400	4800	HK 5020	BK 5020	67.3	82.9
	58	24	33.8	78.5	3400	4800	HK 5024	BK 5024	82.3	97.9
	58	25	85.8	287	3400	4800	FY-5025/D	FY型	77.6	
	62	30	62.7	112.4	3400	4800	HK 5030	HK型	160	
	62	45	85.5	168.2	3400	4800	HK 5045/AS1	Hk型	250	

推力滚针轴承垫圈 **XH**
Thrust needle roller bearing washer

图示 Illustration

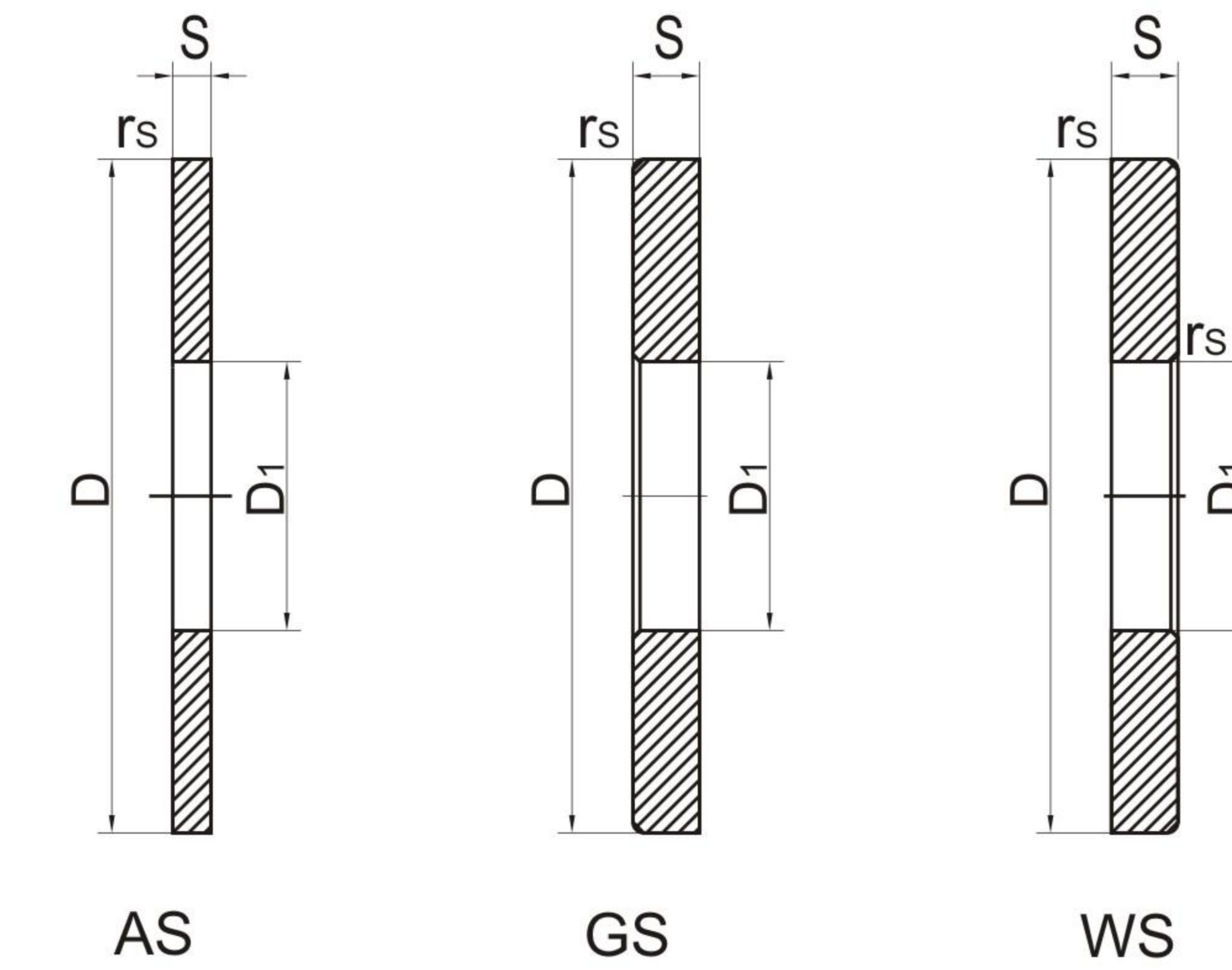

产品介绍:

推力垫圈 (AS系列) 是用轻淬火的弹簧钢制成的, 滚道经过抛光。可与推力滚针和保持架组成 (AXK) 配套使用, 厚度仅为 0.8mm 或 1mm 的推力垫圈是一种非常经济而占据空间又极小的支撑。轴圈和座圈 (WS/GS 系列) 与推力圆柱滚子和保持架组件配套使用。他们由滚动轴承钢经淬火制成, 滚动表面经磨削并抛光。

Product introduction:

Thrust washers (AS series) are made of light-quenched spring steels with raceways polished. They can be used with thrust needles and cages as complete sets (AXK series). With thickness of 0.8mm or 1mm, the thrust washers work as supports which are very economical and occupy small space. Shaft washers and races (WS/GS series) are used with thrust cylindrical rollers and cage assemblies as complete sets. They are made of light-quenched rolling bearing steels with raceway surface ground and polished.

序号 No.	轴承代号 Bearing designation	外形尺寸 Boundary dimensions (mm)		
		D1	D	S
1	AS0614/8	6	14	0.8
2	AS173001	17	30	1
3	AS2130/08	21	30	0.8
4	AS2542/08	25	42	0.8
5	AS304210	30	42	1
6	AS406001	40	60	1
7	CP4565	45	64.4	0.8
8	AS557801	55	78	1
9	TRA-3648	57.15	76.2	0.8
10	AS608510	60	85	1
11	WS81103	17	30	2.75
12	GS81103	18	30	2.75
13	WS40653	40	65	3
14	GS42653	42	65	3
15	AS0515	5	15	1
16	AS5.517/05/YB4	5.5	17	0.5
17	AS0619	6	19	1
18	AS6*19*1.2	6	19	1.2
19	AS6.2*11*0.5	6.2	11	0.5
20	AS6.2*15*0.5	6.2	15	0.5
21	TRA-411	6.4	17.45	0.8
22	AS6.6*11*0.5	6.6	11	0.5
23	AS0715/08	7	15	0.8
24	ASA0816	8	16	0.8
25	AS0821	8	21	1
26	AS8.2*13.7*0.5	8.2	13.7	0.5
27	Washer 8.2*17.2*1	8.2	17.2	1
28	AS09*17*1	9	17	1
29	AS1020	10	20	1
30	AS102201	10	22	1
31	AS1024	10	24	1